

Dr Oliver Mathematics
Advanced Level Mathematics
AS Mechanics: Calculator
1 hour 15 minutes

The total number of marks available is 30.

You must write down all the stages in your working.

Note: It goes with the AS Statistics paper.

1. At time $t = 0$, a parachutist falls vertically from rest from a helicopter which is hovering at a height of 550 m above horizontal ground.

The parachutist, who is modelled as a particle, falls for 3 seconds before her parachute opens.

While she is falling, and before her parachute opens, she is modelled as falling freely under gravity.

The acceleration due to gravity is modelled as being 10 ms^{-2} .

- (a) Using this model, find the speed of the parachutist at the instant her parachute opens. (1)

When her parachute is open, the parachutist continues to fall vertically.

Immediately after her parachute opens, she decelerates at 12 ms^{-2} for 2 seconds before reaching a constant speed and she reaches the ground with this speed.

The total time taken by the parachutist to fall the 550 m from the helicopter to the ground is T seconds.

- (b) Sketch a speed-time graph for the motion of the parachutist for $0 \leq t \leq T$. (2)
- (c) Find, to the nearest whole number, the value of T . (5)

In a refinement of the model of the motion of the parachutist, the effect of air resistance is included before her parachute opens and this refined model is now used to find a new value of T .

- (d) How would this new value of T compare with the value found, using the initial model, in part (c)? (1)
 - (e) Suggest one further refinement to the model, apart from air resistance, to make the model more realistic. (1)
2. A small ball, P , of mass 0.8 kg, is held at rest on a smooth horizontal table and is attached to one end of a thin rope.

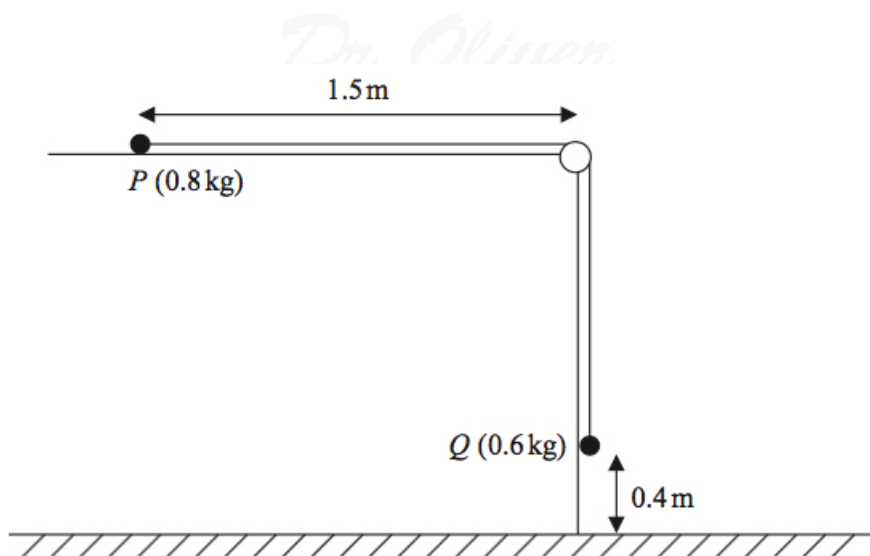

Figure 1: P , of mass 0.8 kg, and Q , of mass 0.6 kg

The rope passes over a pulley that is fixed at the edge of the table. The other end of the rope is attached to another small ball, Q , of mass 0.6 kg, that hangs freely below the pulley.

Ball P is released from rest, with the rope taut, with P at a distance of 1.5 m from the pulley and with Q at a height of 0.4 m above the horizontal floor, as shown in Figure 1.

Ball Q descends, hits the floor, and does not rebound.

The balls are modelled as particles, the rope as a light and inextensible string, and the pulley as small and smooth.

Using this model,

(a) show that the acceleration of Q , as it falls, is 4.2 ms^{-2} , (5)

(b) find the time taken by P to hit the pulley from the instant when P is released. (6)

(c) State one limitation of the model that will affect the accuracy of your answer to part (a). (1)

3. A particle, P , moves along a straight line such that at time t seconds, $t \geq 0$, the velocity of P , $v \text{ ms}^{-1}$, is modelled as

$$v = 12 + 4t - t^2.$$

Find

(a) the magnitude of the acceleration of P when P is at instantaneous rest, (5)

(b) the distance travelled by P in the interval $0 \leq t \leq 3$. (3)